

Universal Splitters SP-0, SP-1, SP-2, SP-2.5, SP-3, & SP-33

OPERATING INSTRUCTIONS

1. Adjust splitter bars for desired chute width as follows:
 - A. Loosen two wing nuts, one on each end of splitter.
 - B. Lock the hopper in the "open" position by using the Safety Lock beside the hand lever. **(NOT necessary on Models SP-0, SP-3, and SP-33.)**
 - C. Flip the adjustable chute bars back and forth to form alternate right and left chutes of desired width. A chute width of two to three times materials topsize is recommended. Check to be sure the width chosen results in the same number of chutes in either direction.
 - D. Tighten wing nuts, remove Safety Lock, and close hopper.
2. Place sample in closed hopper, distributing as you pour, and level by hand until material is evenly distributed from side-to-side and from front to back in hopper. Position pans.
3. Open gates of hopper using a smooth, rather fast motion of the hand lever. Sample will divide to half the original portion in each of the bottom pans.

NOTE: Hopper gate of Models SP-3 and SP-33 are spring loaded and lever is merely released from holding notch to open hopper.

4. If a smaller sample fraction is needed, transfer portion in one pan to closed hopper, level, and split again. Repeat until the desired fraction is reached, 1/4, 1/8, 1/16, 1/32, etc.
5. Sampling accuracy can only be as good as the methods employed. We suggest the following additional tips be employed as part of your standard sampling procedures:
 - A. Prior to splitting your sample fraction, mix the sample by repetitive dividing and recombining entire sample in the hopper. Repeat until starting sample is thoroughly mixed.
 - B. When pouring samples into hopper, always use care to distribute material back and forth in layers as you pour.



SP-2

- C. If bridging or hang-up of material occurs in the chute bar area, reset the splitter for wider chute widths.
- D. Always be sure your chute bar setting gives an equal number of alternating chutes in each direction. The following chute openings are permissible:

Model SP-0:	1in, 2in, 3in, 4in, 6in, 8in, 12in
Model SP-1:	1/2in, 1in, 1-1/2in, 2in, 3in, 4in, 6in
Model SP-2:	1/2in, 1in, 1-1/2in, 3in
Model SP-2.5:	1/4in, 1/2in, 3/4in, 1in, 1-1/2in, 2in, 3in
Models SP-3 & SP-33:	1/8in, 1/4in, 3/8in, 1/2in
- E. When using Model SP-0, material in the two pans on one side of the splitter should be treated as a single sample – i.e. combine the two when re-splitting or for retention of final sample.

(Continued on back.)

Rev: 01/2019

6. To position chute attachment on Model SP-1, remove wing nuts from the studs on back of splitter. Insert top of bag loading chute over support angles that normally hold material pan, fitting holes over threaded studs. Replace wing nuts. With bag-tightening lever in horizontal position (right or left), draw top of bag over sharp corners of chute bottom and reverse fold bag on top of bag-tightening lock tab. Lift lever to secure bag.
7. Models SP-0, SP-2.5, SP-3, and SP-33 are manufactured with 60° chute slopes as required for coal or coke (ASTM D 2013, D 346) or for other materials requiring steep slope for proper sample flow. Other models may be easily changed to 60° from standard 45° chute slopes by adding the following adapter kits in the field:

Kit for SP-1	Model SPA-103
Kit for SP-2	Model SPA-106

SP-2.5 ONLY

Two position stop is used on hopper gate lever. When in Position 1, safety stop holds hopper open during cleaning or bar adjustment. Position 2 controls the maximum amount hopper can open. Failure to utilize this stop may allow material to feed outside of chute area.

POSITION 1

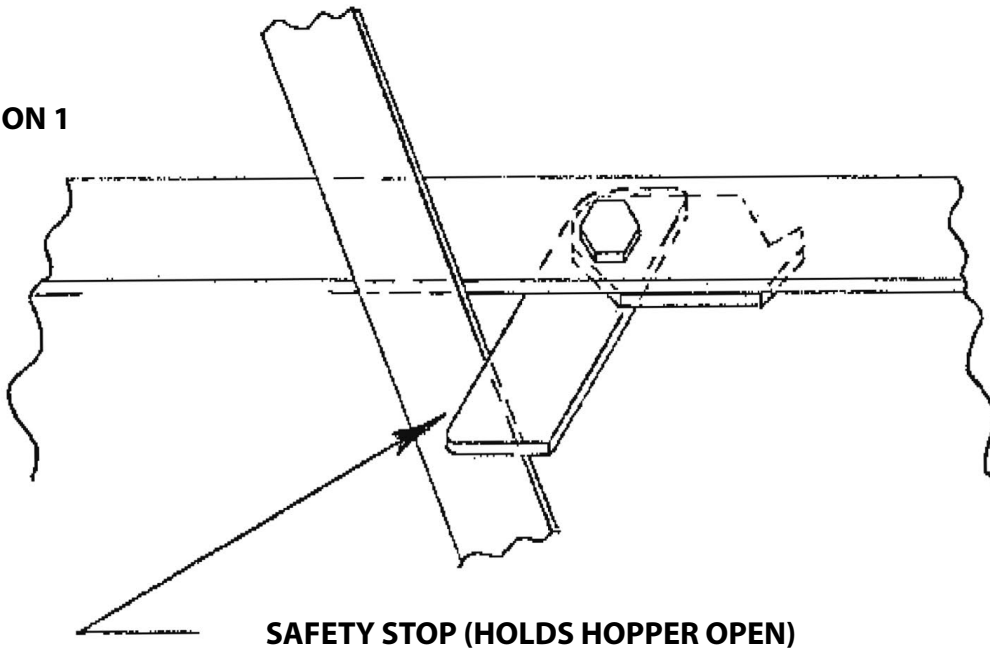

POSITION 2

