

Gilson Universal Fixed Chute Splitter SP-1C

OPERATING INSTRUCTIONS

1. Place sample in closed hopper, distributing as you pour, and level by hand until material is evenly distributed from side-to-side and from front to back in hopper. Position pans.
2. Open gates of hopper using a smooth, rather fast motion of the hand lever. Sample will divide to half the original portion in each of the bottom pans.
3. If a smaller sample fraction is needed, transfer portion in one pan to closed hopper, level, and split again. Repeat until the desired fraction is reached, 1/4, 1/8, 1/16, 1/32, etc.
4. Sampling accuracy can only be as good as the methods employed. We suggest the following additional tips be employed as part of your standard sampling procedures:
 - A. Prior to splitting your sample fraction, mix the sample by repetitive dividing and recombining entire sample in the hopper. Repeat until starting sample is thoroughly mixed.
 - B. When pouring samples into hopper, always use care to distribute material back and forth in layers as you pour.
 - C. Excessive bridging or hang-up of material in the chute bar area is an indication that the particle size of the material is too large for the chutes. Contact Gilson Technical Support for guidance.
5. To position the optional chute attachment, remove wing nuts from the studs on back of splitter. Insert top of bag loading chute over support angles that normally hold material pan, fitting holes over threaded studs. Replace wing nuts. With bag-tightening lever in horizontal position (right or left), draw top of bag over sharp corners of chute bottom and reverse fold bag on top of bag-tightening lock tab. Lift lever to secure bag.



SP-1C

(Continued on back.)

Rev: 01/2019

SAFETY AND LEVER STOP OPERATION

Two position stop is used on hopper gate lever. When in Position 1, safety stop holds hopper open during cleaning or maintenance. Position 2 controls the maximum amount hopper can open. Failure to utilize this stop may allow material to feed outside of chute area.

POSITION 1

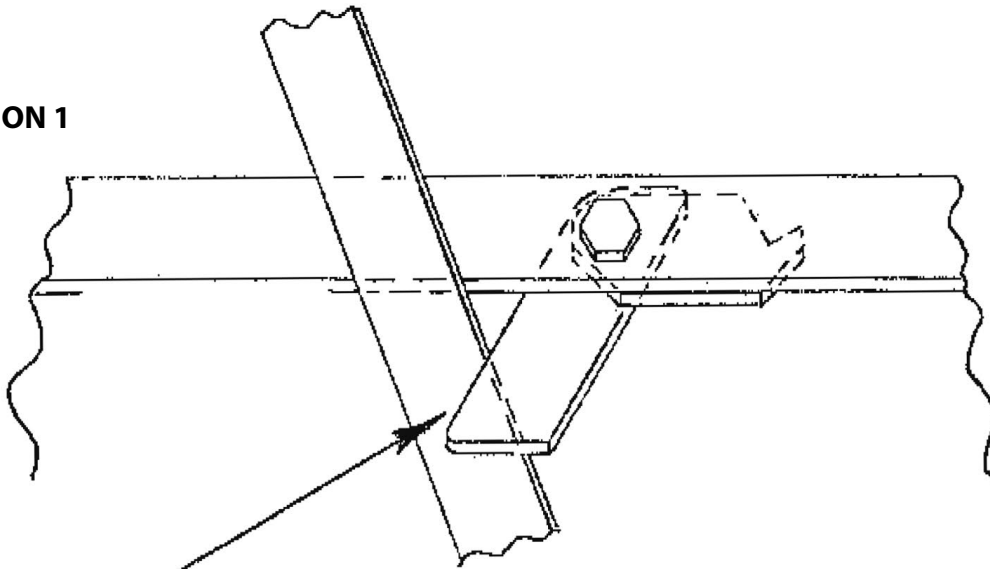

SAFETY STOP (HOLDS HOPPER OPEN)

POSITION 2

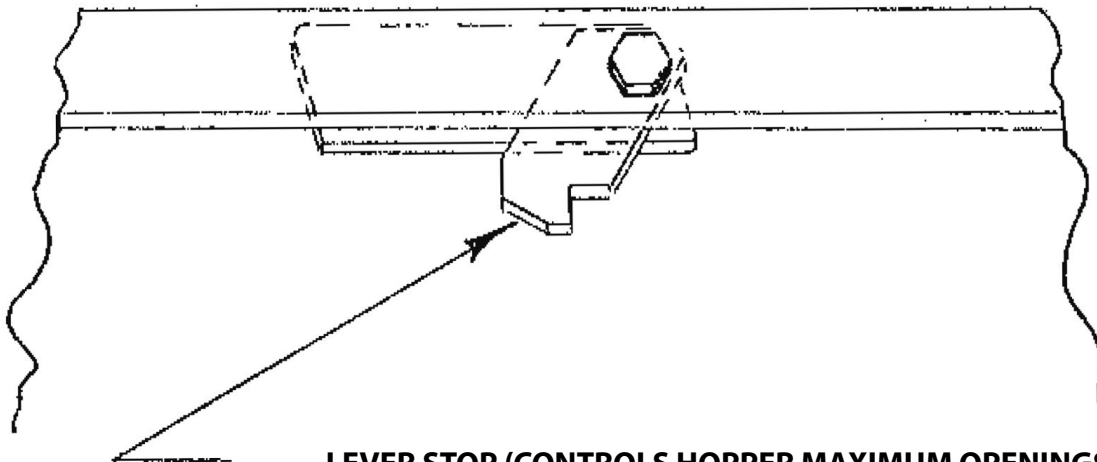

LEVER STOP (CONTROLS HOPPER MAXIMUM OPENINGS)